

TMEZ-SC

Anyone can be an embroidery specialist.

THE WORLD'S FIRST embroidery machine with automatic thread tension adjustment.

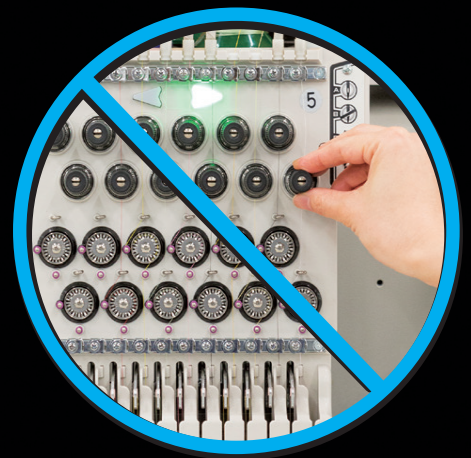

No more tension knobs!



i-TM is mounted on the tension base in place of the previous tension knobs.



- No upper thread manual tension adjustment for the operator
- Automatic tension adjustment based on thread type
- Automatic tension adjustment for a change from run to satin stitches
- The presser foot automatically detects the fabric thickness
- Automatic evaluation of upcoming stitch types and adjusting according to stitch length, stitch direction, type of stitch, machine speed and thickness of the fabric

The amount of upper thread supply is automatically calculated according to the stitch type.

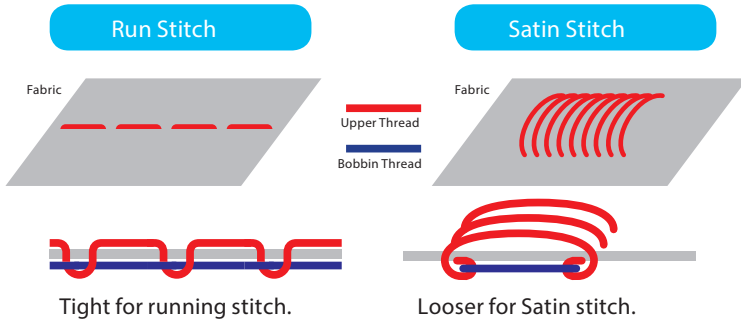

Improved production efficiency

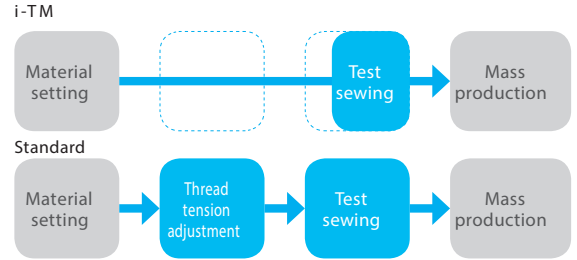

As the appropriate thread tension adjustment is applied regardless of the thread type, mass production can be started quickly.

Reduces fabric pinching

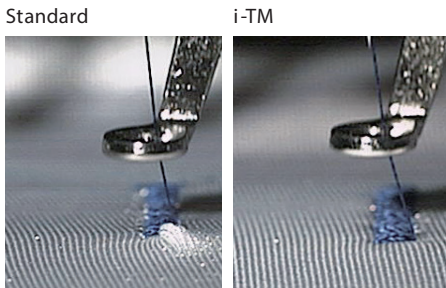

Fabrics can sometimes become pinched depending on the type and sewing conditions.

Digitally Controlled Presser Foot



The height of the presser foot can be randomly set according to the material thickness on the operation panel. The fabric does not flutter even when using hard-to-embroider materials like leather, thick fabric, stretchy fabric and quilting.

Touch screen panel



The touch screen panel has picture icons to guide you and has high-capacity memory that can store up to 40 million stitches or 650 designs.

Specifications

Needles	15
Factory options	Position Marker, LED Lamp
Dealer options	Stand, Stand Tray, Border Frame, Cap Frame 2
Revolution	Max. 1,200 rpm
Electricity	Single-phase 100-120V, 200-240V, 50Hz/60Hz
Power consumption	160W
Weight	95kg/209lbs *294lbs with included stand

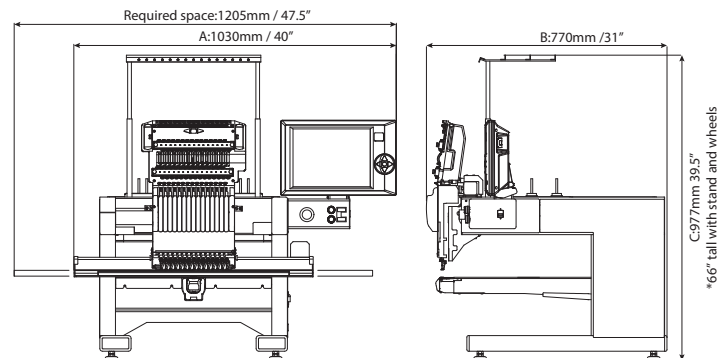

www.hsi.us
care@hsi.us
 800.394.4426

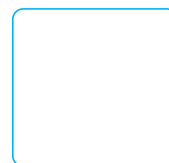

Watch videos

